

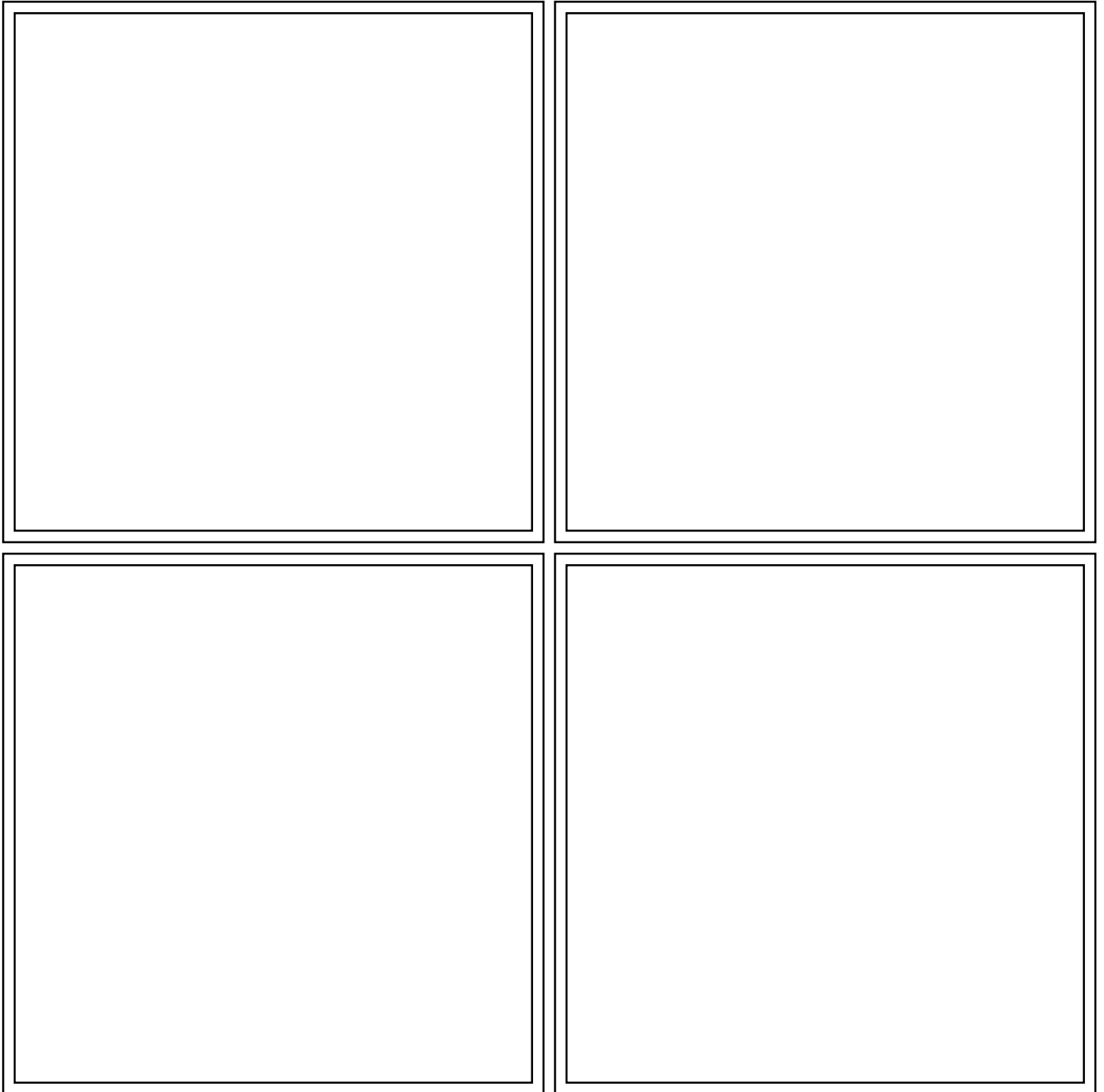

Réf. 1596 - O33 / b - 1.95



D.C. MOTORS

Installation and maintenance

D.C. motors

Receipt - Storage

Commissioning

In order to obtain complete satisfaction from your new LEROY-SOMER motor, it is important to comply with the following instructions.

IMPORTANT :

Contact with any live or rotating parts may cause injury. Never touch the motor casing during operation, as this is likely to become very hot.

Installation, servicing and maintenance must only be carried out by a qualified member of staff.

LEROY-SOMER cannot be held responsible for any problems arising from failure to comply with the instructions in this manual.

1. - RECEIPT

Initial checks :

- As soon as you receive the machine, ensure that the identification plate conforms with the contract specifications;
 - Next, inspect the state of the machine after delivery.
- In the event of any damage having been caused by transportation, notify your haulage contractor.

2. - STORAGE

2.1 - Storage area

The storage area must be dry, and sheltered from the elements. With a minimum temperature of -40°C , it should not be subject to frequent temperature variations (to avoid the risk of condensation), and should be free from vibration, dust and corrosive gases.

When motors are stored for a relatively long time certain precautions need to be taken.

2.2 - Long-term storage (> 3 months)

- Remove the brushes, or wrap cardboard around the commutator to prevent it being marked by dry electrolysis.
- Place the motor in a horizontal position in a sealed watertight package (heat-sealed bag, for example) containing a dehydrating sachet large enough to protect the machine, taking account of its size and the humidity in the storage area.

3. - ENVIRONMENT

Rated characteristics for these motors have been established assuming a normal environment (defined in IEC 34.1) :

- altitude 1000 m or less
- temperature between $+5$ and $+40^{\circ}\text{C}$.

More stringent specifications can be accommodated by derating if the particular requirements are stated at the time of ordering.

4. - COMMISSIONING

BEFORE INSTALLATION

If the motor has been stored for several months, it is essential to check that :

- the inside is clean and free of condensation;
- the commutator looks in good order, and the brushes move freely once replaced in their cage (take care to put them in the right way round);
- the motor is correctly insulated (minimum of $>1\text{ M}\Omega$ powered at 500 V.D.C. for 60 seconds) after disconnection of all the electronic circuits, if necessary.

WARNING : *Do not apply the megohmmeter to the thermal detector terminals, as this may damage them.*

- Take the cardboard out from around the commutator, if appropriate.

If the correct insulation value is not reached, the motor should be dried out as follows :

4.0.1 - By heating externally

- Place the motor in an oven at 80°C , ensuring all openings are free of obstruction, for about 12 to 20 hours until the correct isolation is obtained.

- Take care to raise the temperature gradually to avoid condensation.

- While drying, make regular checks on the insulation values which will tend to fall initially and then rise.

4.0.2 - By heating internally (except for "series-wound" motors)

Supply power to the field excitation only at 30% of its rated value (doors open) and check the increase in insulation values. Do not run the auxiliary fan during this operation.

4.1 - Installation

- Check that the power supply to the motor corresponds with the characteristics on the motor identification plate and accessories (FV, DC Tacho, Brake, etc) and that these are as ordered. See our general technical catalogue for details of power supply conditions.

- Couple the motor, taking care that it is correctly aligned; ensure that the supporting plate is firm and level (foot-mounted motors).

- Check that :

- The rotor turns freely by hand : it should not stick or catch at any point;
- The brush-holder is correctly positioned (ring/flange and flange/ring marking) : this has been identified during tests at the factory, and its position should not be altered;

• Pulleys or jointing sleeves should be balanced to correspond to the motor balancing :

- I.E.C. motors are balanced according to ISO 8821 with a letter on the shaft end denoting : "F" full shaft key, "H" half shaft key and "N" no shaft key.

- N.E.M.A. motors are balanced with a half shaft key.

• The drive belts are correctly tensioned (see our technical catalogue for the maximum admissible radial force).

If the commutator has oxidised, use a grindstone to remove the rust : see section 5.2.1 for the correct procedure.

D.C. motors Servicing

Motors should be installed in a location where cooling air (which must be low in humidity, free of dust, steam and corrosive gases) can enter and exit freely. Ensure that warm air emissions cannot be drawn back in (motor against a wall for example).

- Remove the anti-rust protection on the shaft and flange (for flange-mounted or foot and flange-mounted motors); do not use any abrasive material, but rather a cloth soaked in alcohol or solvent.

- Check that all the protective wrapping has been removed.

N.B : *Do not operate the motor with the inspection doors open for more than five minutes.*

4.2 - Connection

- Connect the motor using cables of an appropriate size. Be particularly careful when screwing on the terminal nuts (if done incorrectly, this could damage the connections by overheating : see diagram below).

- During installation, include safety devices to protect the motor.

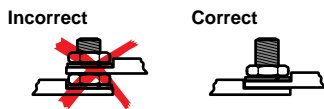

- Cables and connectors must be of an appropriate size for the current.

- Check also that connectors are crimped onto the cables.

- For cables fed from above : make a kink in the cable before the cable gland (water drop effect : see opposite).

- With the motor on-load, check that switching is occurring correctly.

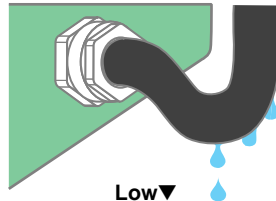

5. - SERVICING

Normal service intervals are indicated in the product manual. Most brushes are marked with a minimum usage level. Once this mark is reached, the brush should be replaced.

- Check all fixings and electrical connections are fully tightened (1st service visit).

- Clean the inside of the motor with dry, clean compressed air (maximum 6 bars pressure).

- Check the state of the bearings.

5.1 - Brushes

- Check that the brushes move freely within the brush-holder. When a brush is lifted 3 or 4 mm from its cage, it should fall back sharply onto the commutator.

- Check that each brush is subject to the same pressure.

- Check their appearance : the friction surface must be shiny, not stained, scratched or burnt, and the side panels matt, not glazed.

- Check the degree of wear. Do not wait until brushes are completely worn down before replacement. Only replace brushes (the complete assembly) with parts of the original quality or equivalent, as defined by LEROY-SOMER.

- Each time the brushes are changed, they must be run in (see section 5.2).

- **Never remove a brush while the motor is running.**

- After removing a brush, always replace it in its original position.

- If the motor is fitted with brush(es) with wear detectors, it is (they are) attached to the negative pole (A2 terminal unless otherwise specified).

5.2 - Running in new brushes



Each time the brushed are changed, they must be run in.

WARNING : This operation must be performed by a **qualified member of staff**.

Should this have to be done while the motor is powered up, follow the safety instructions closely. **Before touching the brushes, you must read the UTE C18-510 standard with regard to operator protection (special insulating gloves, safety glasses, etc) as well as any current laws and regulations affecting the safety of personnel.**

The brushes must be abraded with a special stone through the opening on the end flange, or with a 60 to 80 grain sanding belt.

5.2.1 - Abrasion with a grindstone (power on, motor at no load) :

- Tilt the stone (BARRE AS 320SPK or IDEAL 23 003H) in the direction of rotation while pressing gently : take care not to touch any live parts.

5.2.2 - Abrasion with emery strip (power off) :

- Position the belt (60 to 80 grain side **facing the brush**, see diagram below) between the commutator and the brush.

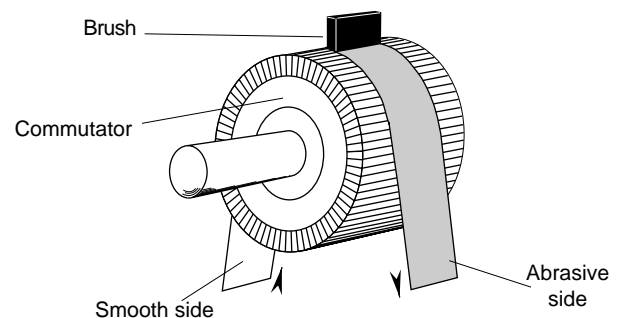

- Move the belt back and forth until the whole of the brush surface has been treated.

After abrasion, remove the brushes and the plug from the hole located under the end flange (if necessary), and blow any dust away.

5.3 - Commutator

When new, the surface is shiny, and copper-coloured. After a few hours of operation, a dark shiny tinge appears evenly over the surface of the commutator, known as the patina. This micro-layer of copper oxide mingled with brush particles forms a coating which protects the commutator and reduces the amount of wear on the brushes. This is quite normal and a sign of correct operation.

D.C. motors

Servicing - Ordering spare parts

The commutator should always appear polished and should run true.

If the blades are badly worn, the insulator may come into contact with the surface of the commutator. This may then become misshapen (more than 4 or 5/100th out of true as against the dial gauge), scratched, or badly worn; the commutator must then be removed for machining.

Machining involves rotating the commutator and remilling the mica. It should only be carried out by a **qualified** mechanic at a workshop approved by LEROY-SOMER using the following method :

- Turn the rotor once;
- Check concentricity of bearing with dial gauge;
- Turn the commutator with a carbide-tipped tool at a speed of approximately 200 m/min, advancing 0.3 mm/turn for the rough cut, 0.1 mm/turn for finishing;
- Rub or mill the micanite segments to a depth of 1 to 1.5 mm below the surface.

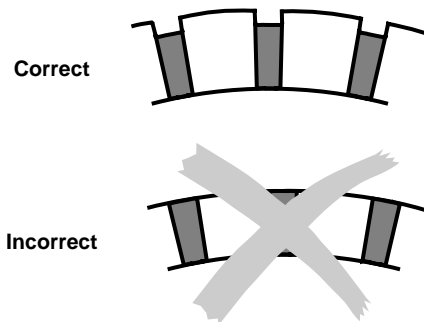

Important : Never clean the commutator with an abrasive cloth, solvents or high-pressure cleaning agents, as these will destroy the patina : simply use a clean dry cloth. When the commutator has been replaced, it is advisable to readjust the distance between the brush-holder and the commutator by 1 or 2 mm max if possible. Once the motor is restarted, the commutator will need to be run in using a grindstone (see section 5.2.1).

5.4 - Filter

Where motors are fitted with filters, the state of these must be checked regularly. Intervals between cleaning (2 days to 1 month) essentially depend on the level of ambient air pollution and the type of duty.

5.4.1 - Dry dust :

The filter should be laid down for cleaning either by injecting compressed air against the clogged side, or by spraying water at both sides of the filter, starting with the clean side.

5.4.2 - Greasy dust :

To unclog the filter, soak the filter in cold or warm water with a little detergent.

Warning : Do not rub or wring the filter, as this will weaken the fibres of the bonding material, rendering the filter unusable.

Make sure the filter is completely dry before replacing.

N.B : In the event of a major incident affecting either

the power supply device or operation downstream, the motor should be given a thorough check : state of the commutator, brush-holder assembly, etc.

6. - BRUSH-HOLDER

The motor is normally supplied with the brush-holder set in position, which has been marked after testing. If the rotor is replaced, the brushes will require readjustment. For maximum performance, it is useful to make identification marks before removing the brushes if the factory markings (flange / casing and brush-holder / flange) are no longer visible.

If the position has not been marked, set the brush-holder in place as follows :

- Disconnect the rotor from the power supply ;
- Connect a millivoltmeter (see diagram above);

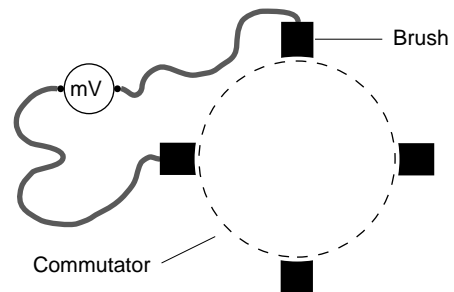

- Apply a D.C. or rectified voltage to the field winding (1.5 V for a motor with "series-wound" field excitation, otherwise field voltage as per the identification plate);

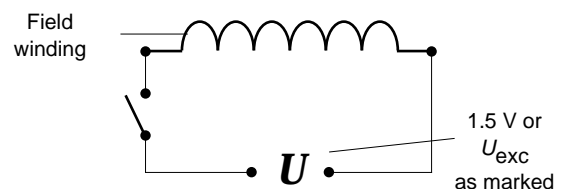

- Switching the current off and then on again causes the induction of a voltage in the rotor indicated by the millivoltmeter. Needle deviation increases the further one goes from the dead line. It is minimal or non-existent on the dead line.

- Fix the brush-holder in place and mark the position determined accordingly.

7. - ORDERING SPARE PARTS

To ensure efficient after-sales service, each order for spare parts should specify the following elements :

- Motor type and serial n°
- and for each part :
- Part description and (or) identification n°;
 - Quantity ordered.

For instant identification, please give the reference for the document used for ordering (plan or manual n°). Details of the type and serial n° appear on the motor identification plate.