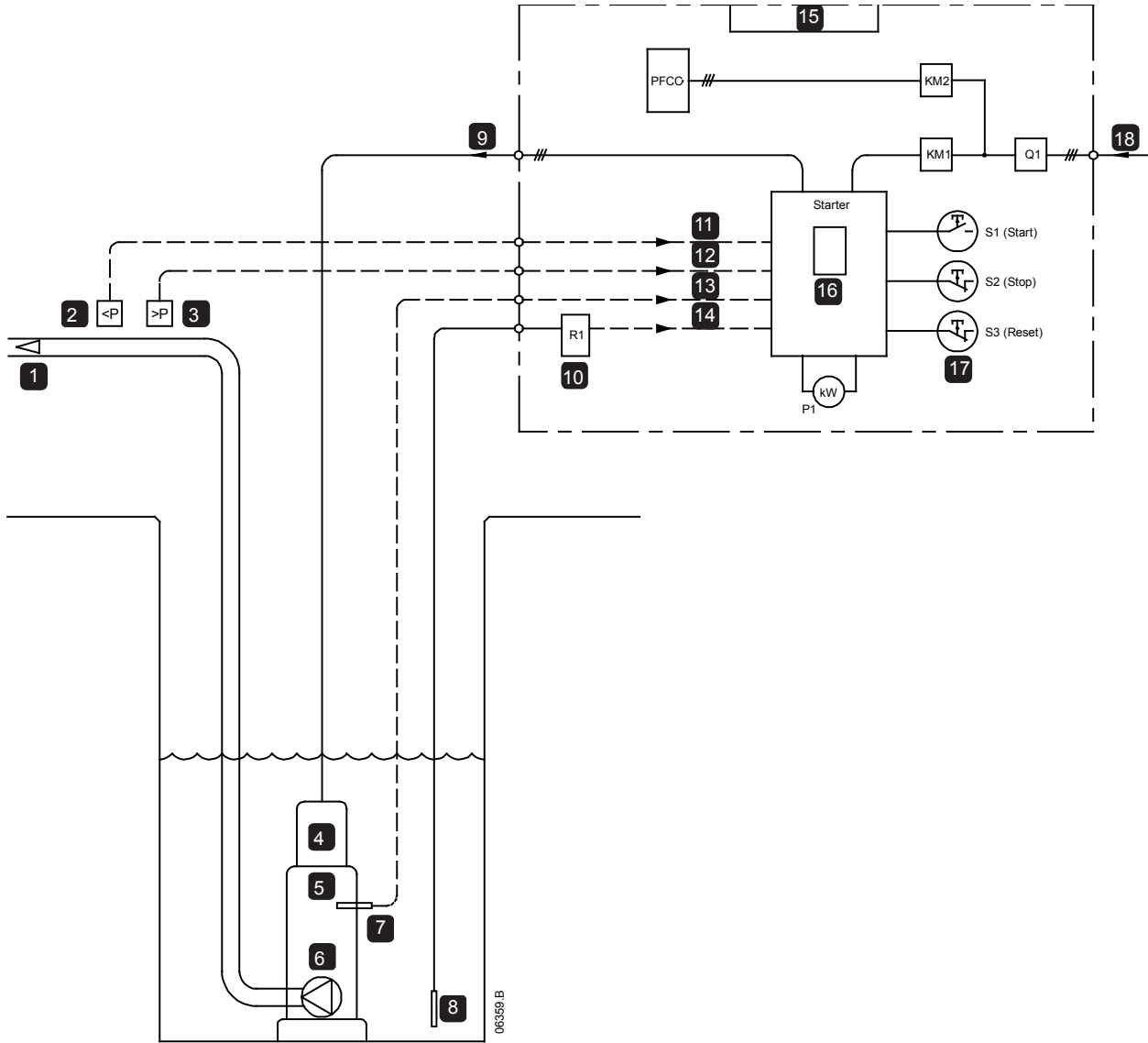

1 Description

The Digistart D3 can provide a total pumping solution without the installation costs of extra control equipment. The Digistart D3 includes a number of features which make it ideal for any pumping situation:

- The new Adaptive Acceleration Control can be used to optimise pump start and stop performance – No more pressure surges or release valve problems during pump starting and stopping.
- Advanced motor and pump protection features all in one easy-to-use package.
- Automatic start and stop timer function set via the local keypad. Can be set for a predefined start-in / stop-after time or a 24:00 hour starting and stopping time.
- Programmable inputs for direct connection of pressure switches, flow switches, water level relays, etc. Field device activation of these inputs will cause the starter to trip and this condition can be directly displayed on the keypad using assignable text.
- Standard thermistor and RTD (PT100) inputs for direct connection – No need for dedicated external temperature relays.
- Programmable relay outputs for control, indication and interlocking.
- Analog output (0-20mA/4-20mA) indicating current, motor temperature, kW, kVA, power factor and voltage.
- Optional expansion card to expand programmable input and output functionality
- Removable keypad with multiple metering screens which can be door-mounted using an IP65 kit – Eliminates the need for an external door-mounted ammeter, hour run meter and start/stop/reset pushbuttons.
- Internally bypassed. This makes the Digistart D3 ideal for mounting in a totally sealed enclosure – No need for a separate external bypass contactor.

2 Typical Installation

The following diagram illustrates how an Digistart D3 can be used on a typical submersible pump installation. In this example, the Digistart D3 uses three-wire pushbutton control with direct connection of low and high pressure switches, a low water level contact and a PT100 which is monitoring pump temperature. An analog output is used to operate a door-mounted kW meter. Static power factor correction is employed and controlled using the Digistart D3 fixed run output relay.



1	Water flow
2	Low pressure switch
3	High pressure switch
4	Motor
5	Pump
6	Foot valve
7	RTD (PT100)
8	Water level probe
9	Motor supply

10	Water level relay
11	Low pressure (input A)
12	High pressure (input B)
13	Pump temperature (RTD/PT100 input)
14	Low water (input C)
15	Digistart D3 pump panel
16	Digistart D3 keypad (local control and metering)
17	External pushbuttons
18	Mains supply

3 Typical Schematic Diagram

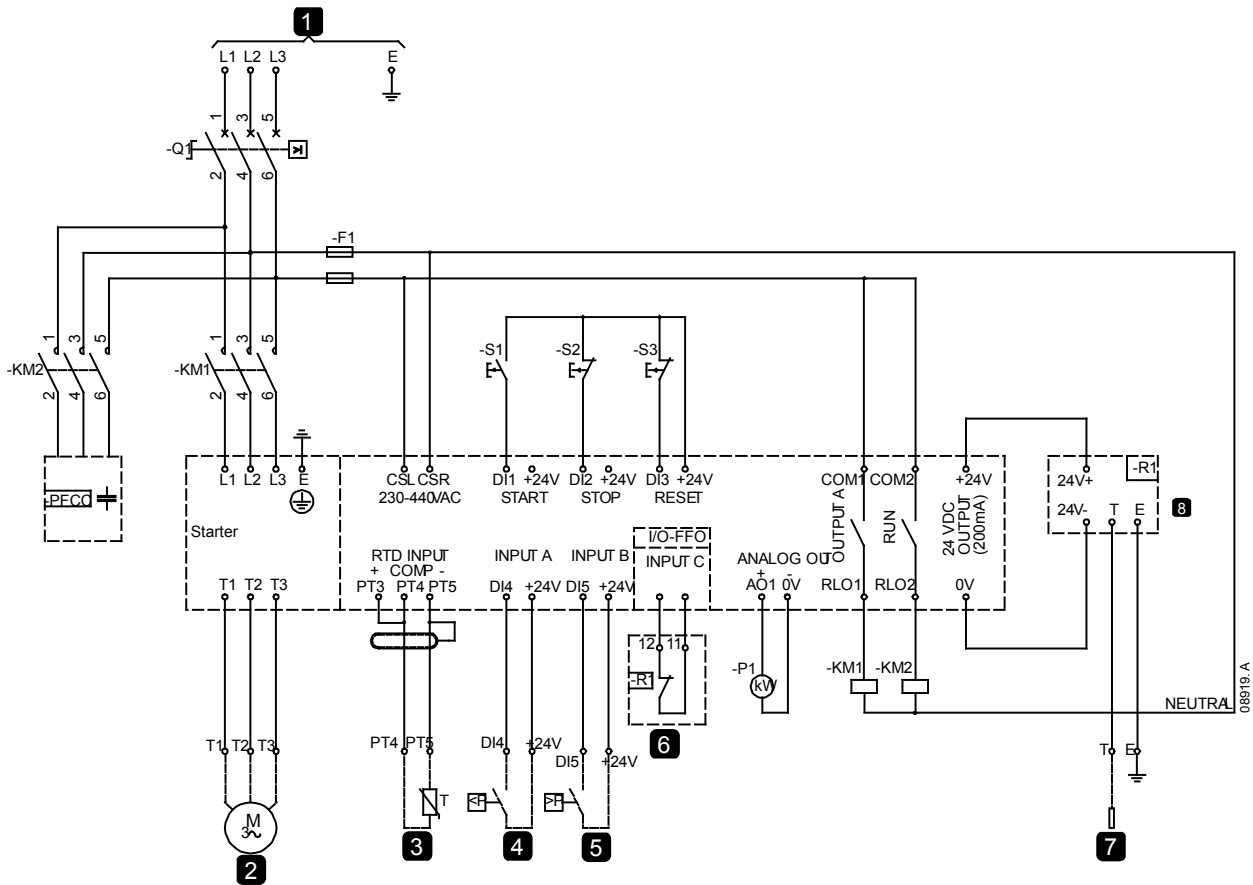

1	Three phase and E supply
2	Pump motor
3	Pump RTD (PT100, 2 wire)
4	Low pressure switch (N/O)

5	High pressure switch (N/O)
6	Low water level (N/C)
7	Water level probe
8	Water level relay

4 Installation and Commissioning Guideline

The following steps are a general guideline and each application will have specific requirements. Refer to the Digistart D3 User Manual when designing your pumping system.

1. Install all associated power cabling
2. Install all associated control wiring. Connect all external devices to the Digistart D3 inputs and outputs. At this stage, do not connect the Low Pressure field device into Digistart D3 Input A
3. Apply control voltage to the Digistart D3 terminals CSH, CSL, CSR (the wiring requirements will depend on the voltage, refer to the User Manual for details).
4. Commission the required start and stop Adaptive Acceleration Control profiles. Use the settings for the primary motor.
5. Commission the programmable output relays and analog output.
6. Set the RTD (PT100) temperature trip point using the RTD Temperature parameters.
7. Start the Digistart D3 under normal load conditions and record the length of time it takes for the system pressure to reach a normal level. Stop the Digistart D3. Use this time to set up programmable Input A for Low Pressure use. Refer to Pr **3A** *Input A Function* and Pr **3D** *Input A Initial Delay*.
8. Connect the Low Pressure field device into Input A (terminals DI4, +24V). Commission the programmable inputs using the Input parameters.
Input A and Input B should be used for Low Pressure and High Pressure detection and associated Digistart D3 tripping. These inputs can be configured for normally open or normally closed field devices, enable input and trip delays can be customised and the keypad can be assigned to indicate "Low Pressure" and "High Pressure" on activation of the associated input.
Programmable Input C should be used for Low Water Level detection and Digistart D3 tripping. The field device must be a normally closed contact and Input C must be set for Emergency Stop using Pr **3K** *Input C Function*.
9. Commission Digistart D3 protections using the Protection Setting parameters.
10. Customise the programmable metering screen as required (eg to display current (A), kW, Hours run, Starter state). Commission this screen using the display parameters.
11. The starter is now ready to operate.